

18.3L NG ENGINE



FEATURES / OPTIONS

- US –EPA Certified and CARB Compliant
- Power: 375kWm Standby on NG
- Integrated Engine Controls Protection with CANBUS
- 50c Ambient Cooling Capacity
- UL2200 Compliant or Listed Components
- MasterTrak Telematics service (included for 1 year)

DESCRIPTION

The NGE 18.3L is a US-EPA CERTIFIED Natural Gas and Propane engine. Built upon a proven marine-diesel grade block, the 10-Cylinder V, turbocharged and after-cooled engine features replaceable wet liners and watercooled exhaust. The engine was developed from the block-up to be a reliable and durable power unit.

Superior engine performance is provided by an ECU that integrates and coordinates all critical functions including: Governor, Variable Ignition Timing, Air:Fuel Ratio Control, Knock Suppression and Engine Protection.

NGEngines is an extension of the Power Solutions, Inc. (PSI) product line which is based upon GM blocks from 650cc to 8.1L. The NGE product lineup has 5 models with displacements of 8.1L, 11.1L, 14.6L, 18.3L and 21.9L. All PSI/NGE engines feature the same fuel systems and controls simplifying your application development and support.

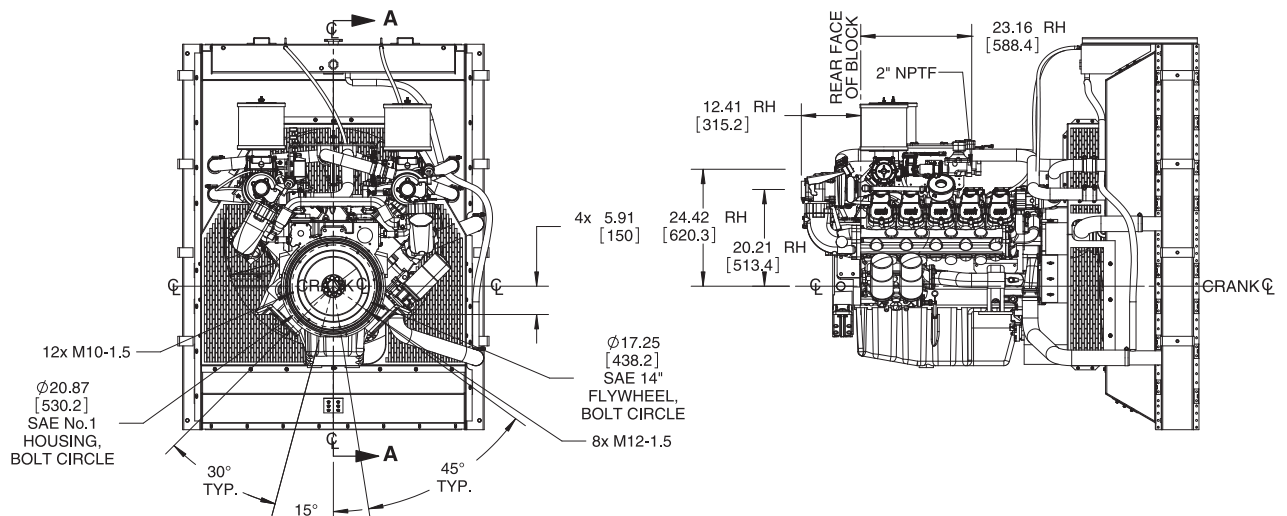



18.3L

	UNITS		18.3L CAC			
	STD	METRIC	1500		1800	
GENERAL ENGINE MOUNTING						
Type	N/A		V-type 4 cycle			
Number of cylinders	N/A		10			
Aspiration	N/A		Turbo Charge Air Cooled			
Bore	in	mm	5.04	128	5.04	128
Stroke	in	mm	5.59	142	5.59	142
Displacement	in ³	L	1115	18.27	1115	18.27
Compression Ratio	N/A		10.5			
Mean Piston Speed	ft/min	m/s	1397.5	7.1	1677	8.52
Rated Load	Hp	kW	428	319	503	375
MEP (@ rated Load)	psi	kPa	203	14	198	14
Rotation Viewed from Flywheel	N/A		Counter Clockwise			
Firing Order	N/A		1-6-5-10-2-7-3-8-4-9			
DRY WEIGHT						
Fan to Flywheel	lb	kg	3400	1542	3400	1542
Rad to Flywheel	lb	kg	4850	2200	4850	2200
WET WEIGHT						
Fan to Flywheel	lb	kg	3562	1596	3562	1596
Rad to Flywheel	lb	kg	5483	2509	5483	2509
CG						
Distance from FW housing	in	mm	6.73	171	6.73	171
Distance above center of crankshaft	in	mm	20.64	524.3	20.64	524.3
ENGINE MOUNTING						
Maximum Allowable Bending Moment at Rear of Block	lb ft	N m	0	0	0	0
Moment of Inertia About Roll Axis	lb ft ²	kg m ²	0	0	0	0
Flywheel housing	N/A		SAE No. 1			
Flywheel	N/A		No. 14			
EXHAUST SYSTEM						
Type						
Maximum allowable Back pressure	in HG	kPa	3	10.2	3	10.2
Standard Catalyst Back pressure	in HG	kPa	1.5	5.1	1.5	5.1
Exhaust Outlet Pipe Size						
Maximum Turbine Inlet Temperature	F	C	1382	750	1382	750
Exhaust Flow at Rated Power	lb/hr	kg/hr	2652	1203	3111	1411
Exhaust Flow at Rated Power @1350F	cfm	m ³ /min	2016	57.1	2366	66.9
AIR INDUCTION SYSTEM						
Maximum allowable Intake Air Restriction with Air Cleaner Clean	inH2O	kPa	5	1.24	5	1.24
Dirty	inH2O	kPa	15	3.74	15	3.74
Combustion Air required	lb/hr	kg/hr	2496	1132	2928	1328
Combustion Air required	cfm	m ³ /min	566	16.6	664	19.4
ELECTRICAL SYSTEM						
Minimum Recommended Battery Capacity	AH		200			
Cold Cranking Current						
Engine only	CCA		1000			
Engine with Drive train	CCA		1000			
Maximum Allowable Resistance of Starting Circuit	Ohms		0.002			
Starting Motor Power	HP	kW	9.4	7	9.4	7
Battery Charging Alternator						
Voltage	Volts		24			
Current	Amps		45			

	UNITS		14.6L CAC			
	STD	METRIC	1500		1800	
COOLING SYSTEM						
Coolant Capacity						
Engine only	gal	L	11	50.0	11	50.0
Engine with Radiator	gal	L	63.5	289	63.5	289
Engine Coolant Flow	gal/min	L/min	145	550	174	660
Water Pump Speed	RPM		0	0	0	0
Heat rejected to Cooling water at rated Load	btu/min	kcal/sec	16832	70.7	20784	87.3
Maximum Intake Air Temperature (IAT)	F	C	155	68	155	68
ECU IAT Warning	F	C	0	0	0	0
ECU IAT Shutdown	F	C	0	0	0	0
Maximum Coolant Friction Head External to the engine	psi	bar	5.8	0.4	5.8	0.4
Maximum Air Restriction Across a Radiator	inH2O	mmH2O	0.5	12.8	0.5	12.8
Standard Thermostat Range						
Cracking Temperature	F	C	160	71	160	71
Full Open Temperature	F	C	185	85	185	85
Maximum Output Pressure of Engine Water Pump						
Maximum Allowable Pressure Cap	psi	bar	14.7	1	14.7	1
Ambient Clearance Open Genset (water)						
Specified	F	C	122	50	122	50
Ambient Clearance (Oil)						
Specified	F	C	122	50	122	50
Maximum Allowable Top Tank Temperature	F	C	230	110	230	110
ECU Warning	F	C	220	104	220	104
ECU Shutdown	F	C	230	110	230	110
Fan Power	HP	kW	16	11.9	28	20.9
Fan Diameter, including blades	in	mm	52	1321	52	1321
Fan Speed	RPM		1200		1440	
Cooling Fan Air Flow @ 1" H2O Stat. Press and 125F @ Rad	CFM	m ³ /min	30857	873.8	36000	1019.4
Charge Air Cooler						
Compressor Outlet Temperature	F	C	0	0.0	0	0.0
Compressor Flow Rate	CFM	m ³ /min	0	0.0	1038	29.4
LUBRICATION SYSTEM						
Oil Specification	SAE 15W-40 Low Ash Gas engine oil (.25-.5% by wt), API CD/CF or higher					
Oil Pressure						
Idle						
Min	Psi	Bar	13	0.9	13	0.9
Max	Psi	Bar	43.5	3	43.5	3
Rated Speed						
Min	Psi	Bar	43.5	3	43.5	3
Max	Psi	Bar	94.5	6.5	94.5	6.5
Maximum Allowable Oil Temperature	F	C	230	110	230	110
Engine Oil Capacity						
Min	Qts	L	29.5	28	29.5	28
Max	Qts	L	37	35.0	37	35.0
Oil Filter Capacity	Qts	L	7.5	7.1	7.5	7.1
FUEL SYSTEM						
Low Pressure Dry Processed Natural Gas (Spec)						
Fuel Composition						
Maximum EPR Rated Pressure	psi	kPa	1	6.89	1	6.89
Maximum Running pressure to Electronic Pressure Regulator (EPR)	inH2O	kPa	11	2.74	11	2.74
Minimum Running pressure to EPR	inH2O	kPa	7	1.74	7	1.74
Minimum Gas Supply Pipe Size			2 x 2" NPT			
Low Pressure Vapor Propane (HD5)						
Fuel Composition						
Maximum EPR Rated Pressure	psi	kPa	1	6.89	1	6.89
Maximum Running Pressure to EPR	inH2O	kPa	11	2.74	11	2.74
Minimum Running Pressure to EPR	inH2O	kPa	7	1.74	7	1.74
Minimum LPG Supply Pipe Size			2 x 2" NPT			

The preceding pipe sizes are only suggestions and piping sizes may vary with temperature, pressure, distance from supply and application of local codes. Gas must be available at adequate volume and pressure for engine at the EPR.