

SG250 | 14.2L | 250 kW
INDUSTRIAL SPARK-IGNITED GENERATOR SET

EPA Certified Stationary Emergency and Non-Emergency

DEMAND RESPONSE READY

Standby Power Rating

250 kW, 313 kVA, 60 Hz

Demand Response Rating

250 kW, 313 kVA, 60 Hz

Prime Power Rating

225 kW, 281 kVA, 60 Hz

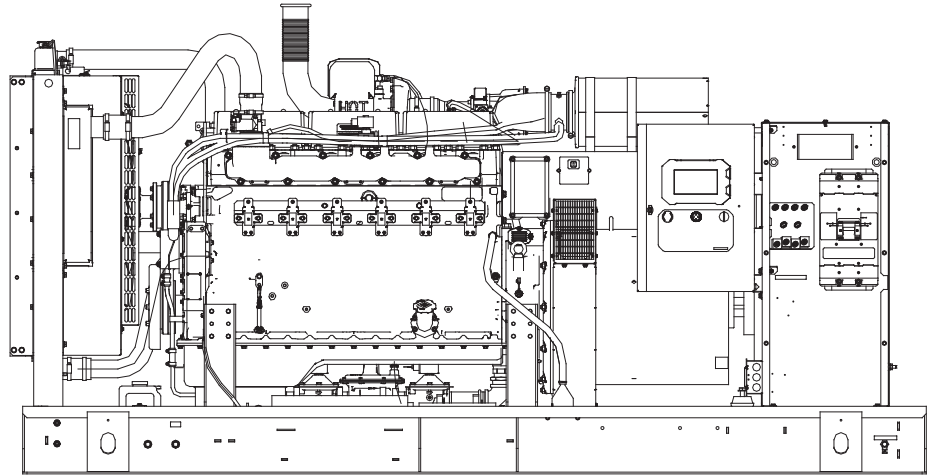

Image used for illustration purposes only



Codes and Standards

Not all codes and standards apply to all configurations. Contact factory for details.

-   UL2200, UL6200, UL1236, UL489
-  CSA C22.2
-   BS5514 and DIN 6271
-  SAE J1349
-  NFPA 37, 70, 99, 110
-  NEC700, 701, 702, 708
-  ISO 3046, 7637, 8528, 9001
-  NEMA ICS10, MG1, 250, ICS6, AB1
-  ANSI C62.41
-   IBC 2009, CBC 2010, IBC 2012, ASCE 7-05, ASCE 7-10, ICC-ES AC-156 (2012)

Powering Ahead

Generac ensures superior quality by designing and manufacturing most of its generator components, such as alternators, enclosures, control systems and communications software. Generac also makes its own spark-ignited engines, and you'll find them on every Generac gaseous-fueled generator. We engineer and manufacture them from the block up — all at our facilities throughout Wisconsin. Applying natural gas and LP-fueled engines to generators requires advanced engineering expertise to ensure reliability, durability and necessary performance. By designing specifically for these dry, hotter-burning fuels, the engines last longer and require less maintenance. Building our own engines also means we control every step of the supply chain and delivery process, so you benefit from single-source responsibility.

Plus, Generac Industrial Power's distribution network provides all parts and service so you don't have to deal with third-party suppliers. It all leads to a positive owner experience and higher confidence level. Generac spark-ignited engines give you more options in commercial and industrial generator applications as well as extended run time from utility-supplied natural gas.

SG250 | 14.2L | 250 kW

INDUSTRIAL SPARK-IGNITED GENERATOR SET

EPA Certified Stationary Emergency and Non-Emergency

STANDARD FEATURES

DEMAND RESPONSE READY

ENGINE SYSTEM

- Oil Drain Extension
- Air Cleaner
- Fan Guard
- Stainless Steel Flexible Exhaust Connection
- Factory Filled Oil and Coolant
- Radiator Duct Adapter (Open Set Only)
- Critical Silencer (Enclosed Units Only)
- Oil Temperature Indication and Alarm

Fuel System

- NPT Fuel Connection on Frame
- Primary and Secondary Fuel Shutoff

Cooling System

- Closed Coolant Recovery System
- UV/Ozone Resistant Hoses
- Factory-Installed Radiator
- 50/50 Ethylene Glycol Antifreeze
- Radiator Drain Extension

Electrical System

- Battery Charging Alternator
- Battery Cables
- Battery Tray
- Rubber-Booted Engine Electrical Connections
- Solenoid Activated Starter Motor

ALTERNATOR SYSTEM

- UL2200 GENprotect™
- Class H Insulation Material
- 2/3 Pitch
- Skewed Stator
- Permanent Magnet Excitation
- Sealed Bearing
- Amortisseur Winding
- Full Load Capacity Alternator

GENERATOR SET

- Internal Genset Vibration Isolation
- Separation of Circuits - High/Low Voltage
- Separation of Circuits - Multiple Breakers
- Wrapped Exhaust Piping
- Standard Factory Testing
- 2 Year Limited Warranty (Standby and Demand Response Rated Units)
- 1 Year Limited Warranty (Prime Rated Units)
- Silencer Mounted in the Discharge Hood (Enclosed Units Only)
- Ready to Accept Full Load in <10 Seconds

ENCLOSURE (If Selected)

- Rust-Proof Fasteners with Nylon Washers to Protect Finish
- High Performance Sound-Absorbing Material (Sound Attenuated Enclosures)
- Gasketed Doors
- Upward Facing Discharge Hood (Radiator and Exhaust)
- Stainless Steel Lift Off Door Hinges
- Stainless Steel Lockable Handles
- RhinoCoat™ - Textured Polyester Powder Coat Paint

CONTROL SYSTEM



Power Zone® Pro Sync Controller

Program Functions

- NFPA 110 Level 1 Compliant
- Engine Protective Functions
- Alternator Protective Functions
- Digital Engine Governor Control
- Digital Voltage Regulator
- Multiple Programmable Inputs and Outputs
- Remote Display Capability
- Remote Communication via Modbus® RTU, Modbus TCP/IP, and Ethernet 10/100
- Alarm and Event Logging with Real Time Stamping
- Expandable Analog and Digital Inputs and Outputs
- Remote Wireless Software Update Capable

- Wi-Fi, Bluetooth, BMS and Remote Telemetry
- Built-In Programmable Logic Eliminates the Need for External Controllers Under Most Conditions
- Ethernet Based Communications Between Generators
- Programmable I/O Channel Properties
- Built-In Diagnostics

Protections

- Low Oil Pressure
- Low Coolant Level
- High/Low Coolant Temperature
- Sensor Failure
- Oil Temperature
- Over/Under Speed
- Over/Under Voltage
- Over/Under Frequency
- Over/Under Current
- Over Load
- High/Low Battery Voltage
- Battery Charger Current
- Phase to Phase and Phase to Neutral Short Circuits (I²T Algorithm)

7 Inch Color Touch Screen Display

- Resistive Color Touch Screen
- Sunlight Readable (1400 NITS)
- Easily Identifiable Icons
- Multi-Lingual
- On Screen Editable Parameters
- Key Function Monitoring
- Three Phase Voltage, Amperage, kW, kVA, and kVAR
- Selectable Line to Line or Line to Neutral Measurements
- Frequency
- Engine Speed
- Engine Coolant Temperature
- Engine Oil Pressure
- Engine Oil Temperature
- Battery Voltage
- Hourmeter
- Warning and Alarm Indication
- Diagnostics
- Maintenance Events/Information

EPA Certified Stationary Emergency and Non-Emergency

CONFIGURABLE OPTIONS

DEMAND RESPONSE READY

ENGINE SYSTEM

- Engine Coolant Heater
- Baseframe Cover/Rodent Guard
- 2 Stage Air Cleaner
- Oil Heater
- Air Filter Restriction Indicator
- Radiator Stone Guard (Open Set Only)
- Level 1 Fan and Belt Guards (Enclosed Units Only)

FUEL SYSTEM

- NPT Flexible Fuel Line

ELECTRICAL SYSTEM

- 10A UL Listed Battery Charger
- Battery Warmer

ALTERNATOR SYSTEM

- Alternator Upsizing
- Anti-Condensation Heater
- Tropical Coating

CIRCUIT BREAKER OPTIONS

- Main Line Circuit Breaker
- 2nd Main Line Circuit Breaker
- Shunt Trip and Auxiliary Contact
- Electronic Trip Breakers

ENGINEERED OPTIONS

ENGINE SYSTEM

- Coolant Heater Ball Valves
- Fluid Containment Pans

CONTROL SYSTEM

- Battery Disconnect Switch

GENERATOR SET

- Demand Response Rating
- Extended Factory Testing (3-Phase Only)
- 12 Position Load Center

ENCLOSURE

- Weather Protected Enclosure
- Level 1 Sound Attenuated
- Level 2 Sound Attenuated
- Level 2 Sound Attenuated with Motorized Dampers
- Level 3 Sound Attenuated (Steel Only)
- Steel Enclosure
- Aluminum Enclosure
- Up to 200 MPH Wind Load Rating (Contact Factory for Availability)
- AC/DC Enclosure Lighting Kit
- Enclosure Heaters (Motorized Dampers Only)
- IBC Certification
- Door Open Alarm Switch

ALTERNATOR SYSTEM

- 3rd Breaker System

GENERATOR SET

- Special Testing
- Battery Box

CONTROL SYSTEM

- NFPA 110 Level 1 Compliant 21-Light Remote Annunciator
- Remote Relay Assembly (8 or 16)
- Remote E-Stop (Break Glass-Type, Surface Mount)
- Remote E-Stop (Red Mushroom-Type, Surface Mount)
- Remote E-Stop (Red Mushroom-Type, Flush Mount)
- 10A Engine Run Relay
- Ground Fault Annunciator
- 100 dB Alarm Horn
- Damper Alarm Contacts (Motorized Dampers Only)
- 120V GFCI and 240V Outlets

WARRANTY (Standby Gensets Only)

- 2 Year Extended Limited Warranty
- 5 Year Limited Warranty
- 5 Year Extended Limited Warranty
- 7 Year Extended Limited Warranty
- 10 Year Extended Limited Warranty

SG250 | 14.2L | 250 kW

INDUSTRIAL SPARK-IGNITED GENERATOR SET

EPA Certified Stationary Emergency and Non-Emergency

APPLICATION AND ENGINEERING DATA

DEMAND RESPONSE READY

ENGINE SPECIFICATIONS

General

Make	Generac
Cylinder #	6
Type	In-line
Displacement - in ³ (L)	864.71 (14.2)
Bore - in (mm)	5.31 (135)
Stroke - in (mm)	6.50 (165)
Compression Ratio	9.5:1
Intake Air Method	Turbocharged/Aftercooled
Number of Main Bearings	7
Connecting Rods	Steel Alloy
Cylinder Head	Cast Iron
Cylinder Liners	Ductile Iron
Ignition	Electronic
Piston Type	Aluminum
Crankshaft Type	Ductile Iron
Lifter Type	Solid
Intake Valve Material	Special Heat-Resistant Steel
Exhaust Valve Material	High Temp Steel Alloy
Hardened Valve Seats	High Temp Steel Alloy

Engine Governing

Governor	Electronic
Frequency Regulation (Steady State)	±0.25%

Lubrication System

Oil Pump Type	Gear
Oil Filter Type	Full-Flow Cartridge
Crankcase Capacity - qt (L)	36.2 (34.3)

Cooling System

Cooling System Type	Pressurized Closed Recovery
Fan Type	Pusher
Fan Speed - RPM	1,894
Fan Diameter - in (mm)	30 (762)

Fuel System

Fuel Type	Natural Gas, Propane
Carburetor	Down Draft
Secondary Fuel Regulator	Standard
Fuel Shut Off Solenoid	Standard
Operating Fuel Pressure - in H ₂ O (kPa)	7 - 11 (1.7 - 2.7)

Engine Electrical System

System Voltage	24 VDC
Battery Charger Alternator	57.5 A
Battery Size	See Battery Index 0161970SBY
Battery Voltage	24 VDC
Ground Polarity	Negative

ALTERNATOR SPECIFICATIONS

Standard Model	K0250124Y21
Poles	4
Field Type	Revolving
Insulation Class - Rotor	H
Insulation Class - Stator	H
Total Harmonic Distortion	<5% (3-Phase)
Telephone Interference Factor (TIF)	<50

Standard Excitation	Permanent Magnet
Bearings	Sealed Ball
Coupling	Direct via Flexible Disc
Prototype Short Circuit Test	Yes
Voltage Regulator Type	Full Digital
Number of Sensed Phases	All
Regulation Accuracy (Steady State)	±0.25%

SG250 | 14.2L | 250 kW

INDUSTRIAL SPARK-IGNITED GENERATOR SET

EPA Certified Stationary Emergency and Non-Emergency

OPERATING DATA

DEMAND RESPONSE READY

POWER RATINGS - NATURAL GAS

	Standby/Demand Response		Prime	
Three-Phase 120/208 VAC @0.8pf	250 kW/313 kVA	Amps: 868	225 kW/281 kVA	Amps: 782
Three-Phase 120/240 VAC @0.8pf	250 kW/313 kVA	Amps: 753	225 kW/281 kVA	Amps: 677
Three-Phase 277/480 VAC @0.8pf	250 kW/313 kVA	Amps: 376	225 kW/281 kVA	Amps: 339
Three-Phase 346/600 VAC @0.8pf	250 kW/313 kVA	Amps: 301	225 kW/281 kVA	Amps: 271

MOTOR STARTING CAPABILITIES (skVA)

skVA vs. Voltage Dip			
277/480 VAC	30%	208/240 VAC	30%
K0250124Y21	630	K0250124Y21	506
K0300124Y21	790	K0300124Y21	609

FUEL CONSUMPTION RATES*

Percent Load	Natural Gas – scfh (m ³ /hr)	
	Standby/Demand Response	Prime
25%	1,020 (28.9)	990 (28.0)
50%	1,620 (45.9)	1,260 (35.7)
75%	2,520 (71.4)	1,980 (56.1)
100%	3,180 (90.0)	2,700 (76.5)

* Fuel supply installation must accommodate fuel consumption rates at 100% load.

COOLING

		Standby/Demand Response	Prime
Air Flow (Fan Air Flow Across Radiator)	scfm (m ³ /min)	10,078 (285.4)	10,078 (285.4)
Coolant Flow	gpm (Lpm)	90 (340.7)	90 (340.7)
Coolant System Capacity	gal (L)	15 (54.9)	15 (54.9)
Maximum Operating Ambient Temperature	°F (°C)	122 (50)	122 (50)
Maximum Operating Ambient Temperature (Before Derate)		See Bulletin No. 0199270SSD	
Maximum Radiator Backpressure	in H ₂ O (kPa)	0.5 (0.12)	0.5 (0.12)

COMBUSTION AIR REQUIREMENTS

	Standby/Demand Response	Prime
Flow at Rated Power - scfm (m ³ /min)	506 (14.3)	455 (12.9)

ENGINE

		Standby/Demand Response	Prime
Rated Engine Speed	RPM	1,800	1,800
Horsepower at Rated kW**	hp	375	337
Piston Speed	ft/min (m/min)	1,950 (594)	1,950 (594)
BMEP	psi (kPa)	190 (1,313)	171 (1,182)

EXHAUST

		Standby/Demand Response	Prime
Exhaust Flow (Rated Output)	scfm (m ³ /min)	1,703 (48)	1,517 (43)
Max. Backpressure (Post Silencer)	inHg (kPa)	0.75 (2.54)	0.75 (2.54)
Exhaust Temp (Rated Output - Post Silencer)	°F (°C)	1,357 (736)	1,340 (727)

** Refer to "Emissions Data Sheet" for maximum bHP for EPA and SCAQMD permitting purposes.

Deration – Operational characteristics consider maximum ambient conditions. Derate factors may apply under atypical site conditions.

Please contact a Generac Power Systems Industrial Dealer for additional details. All performance ratings in accordance with ISO3046, BS5514, ISO8528, and DIN6271 standards.

Standby - See Bulletin 0187500SSB

Demand Response - See Bulletin 10000018250

Prime - See Bulletin 0187510SSB

DIMENSIONS AND WEIGHTS*

DEMAND RESPONSE READY

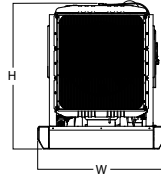
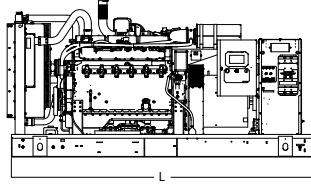

OPEN SET (Includes Exhaust Flex)

L x W x H - in (mm)	136.0 (3,454) x 57.1 (1,450) x 67.9 (1,725)
Weight - lbs (kg)	5,883 - 6,031 (2,668 - 2,735)

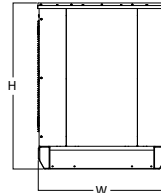
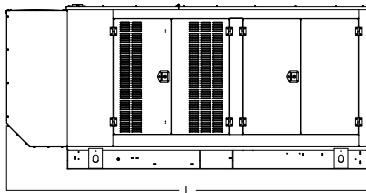

WEATHER PROTECTED ENCLOSURE

L x W x H - in (mm)	174.7 (4,437) x 57.5 (1,461) x 77.8 (1,976)
Weight - lbs (kg)	Steel: 7,448 - 7,596 (3,378 - 3,445) Aluminum: 6,654 - 6,801 (3,018 - 3,084)

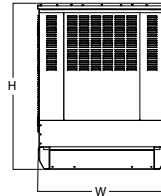
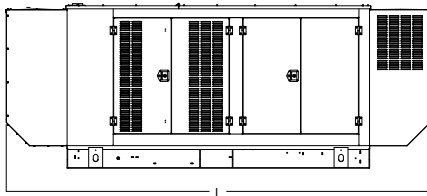

LEVEL 1 SOUND ATTENUATED ENCLOSURE

L x W x H - in (mm)	200.2 (5,085) x 57.5 (1,461) x 77.8 (1,976)
Weight - lbs (kg)	Steel: 7,911 - 8,059 (3,588 - 3,655) Aluminum: 6,853 - 7,000 (3,108 - 3,175)

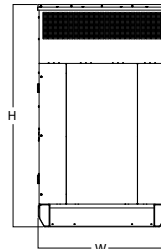
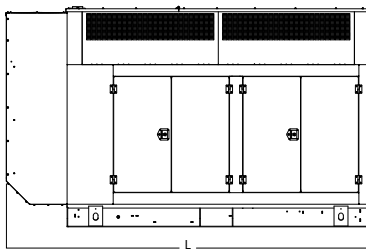

LEVEL 2 SOUND ATTENUATED ENCLOSURE

L x W x H - in (mm)	180.6 (4,587) x 57.5 (1,461) x 111.3 (2,827)
Weight - lbs (kg)	Steel: 8,484 - 8,632 (3,848 - 3,915) Aluminum: 7,099 - 7,247 (3,220 - 3,287)

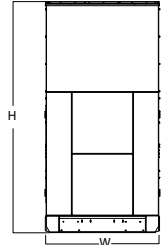
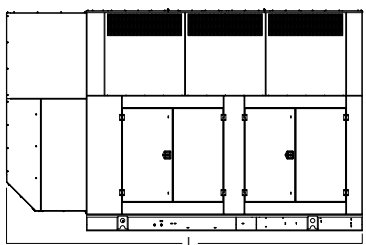

LEVEL 3 SOUND ATTENUATED ENCLOSURE

L x W x H - in (mm)	207.3 (5,265) x 63.7 (1,618) x 128.9 (3,274)
Weight - lbs (kg)	10,840 - 10,990 (4,916 - 4,984)

* All measurements are approximate and for estimation purposes only.

YOUR FACTORY RECOGNIZED GENERAC INDUSTRIAL DEALER

Specification characteristics may change without notice. Please contact a Generac Power Systems Industrial Dealer for detailed installation drawings.